

Effects of Multimedia Instruction on Retention and Achievement of Basic Machining Skills in Mechanical Craft Practice

M. U. Cyril*

Department of Technology Education, Modibbo Adama University of Technology, Yola, Nigeria

Abstract

The emergence of ICT has changed the global status of education. Multimedia instruction which offers alternative to traditional paradigm of learning has made learning more meaningful, accessible and interactive within and outside the classroom. However, Nigeria has not fully embraced the use of multimedia instruction in teaching and learning. Therefore, the study aimed at investigating the effects of multimedia instruction on retention and achievement of basic machining skills in mechanical engineering craft practice. The study was conducted in four selected Technical colleges in Adamawa and Taraba states Nigeria. The population was 252 students in National Technical Certificate (NTC) 2. A sample of 156 were drawn from the population using Yaro Yamane's formula. The design of the study was experimental. The sample drawn were divided into control and experimental groups. Experimental group were taught with multimedia instruction while control group were taught with demonstration method. Instructional video files, and lesson plan, teacher's made test for pretest and posttest, were the instrument developed, validated by three experts and used for data collection. Two research questions and two hypotheses were raised. Mean and standard deviation were used to answer the research questions. t-test statistics was used to test the hypotheses at 0.05 level of significance. The research findings indicated that there is a significance difference between the mean performances of students in the experimental group than those students in the control group. The students in the experimental group performed better in mechanical craft practice and in retention test than those in the control group. Hence multimedia instructions have more effect on learning achievement and retention of skills in craft practice. The study recommended that multimedia instructional tool is an effective tool for enhancing teaching and learning of practical skills in mechanical craft.

Keywords

Multimedia, Instruction, Demonstration

Received: October 15, 2015 / Accepted: November 19, 2015 / Published online: February 24, 2016

© 2016 The Authors. Published by American Institute of Science. This Open Access article is under the CC BY-NC license.

<http://creativecommons.org/licenses/by-nc/4.0/>

1. Introduction

Technical and Vocational Education and Training (TVET) programmes are faced with the challenges of finding innovative ways to accommodate the growing interest in the programmes (Aloraini, 2012). Technical Colleges are not exceptional in this regard. The traditional face to face method, lecture method, demonstration method, field trip etc. have been predominantly used in TVET schools and colleges.

Difficulties associated with traditional teaching methods had contributed to poor levels of academic achievement related to improper teaching and learning strategies employed for teaching technical courses in technical schools and colleges (Nwanekezi & Kalu, 2012; Oshinaike and Adekunmisi, 2012 & Robert, 2011). Udofia, Ekpo, Nsa, and Akpan (2012) noted that inadequate instructional techniques do not enhance

* Corresponding author

E-mail address: ubalecyril@yahoo.com

students' acquisition of skills and development of self-concept as well as interest. It may rather make it difficult for the students to develop the right habit for job performance.

The average school age child spends much time watching television; playing video games and exploring other electronic media devices, including the cell phones (Nwanekezi & Kalu, 2012). These exploration and manipulations according to Nwanekezi and Kalu is a great development in education which have further stimulated interest and created enabling environments for learning to take place both inside and outside the classrooms. Conversely, Idris and Rajuddin (2012a) opined that problem based, context based, and fieldwork teaching methods were significant predictors of technical skills among students. The views of the foregoing authors have undermined the fact that the emergence of Information and Communication Technology (ICT) have created a knowledge based society that have changed the global economy and the status of education (Atsumbe, Ngutor & Enoch, 2012). Moreover, it is essentials for learners to have access to education anytime and anywhere. Hence it is unrealistic to ask students to be in a designated place every time to engage in learning (Atsumbe, et al). Multimedia instruction can deliver instruction anytime and anywhere; and can make instructions available and accessible to learners on multimedia compact discs (CD) and on multimedia files which can be played or viewed on their multimedia mobile devices. This can further facilitates learning outside the school and classroom settings.

The purported strengths of ICT, multimedia technology has made multimedia instruction possible in audio files, video or both files (Gertner, 2011). Multimedia instruction is a vital instrument for transforming traditional paradigm of learning (Mahajan, 2012). Its offers a promising alternative in delivering the intended learning content that may not be available in the traditional face to face instruction (Donkor, 2011). Multimedia instruction has become a powerful medium for explanation of concepts, theories and abstract things which make learning more meaningful (Gupta & Sehgal, 2012). It links the images, audio and visual together to provide a multisensory experience for the learner (El-Sayed & El-Sayed, 2013). Gertner (2011) considered multimedia application to consists of at least three of these seven components: text, data, audio, graphics, photographic images, and animation as well as moving pictures. He further noted that multimedia based lectures provide a unique opportunity to present, teach, and internalize information. Judicious use of multimedia resources can substantially increase the quantity and quality of time spent on task; it offers an excellent avenue for focusing the students' attention on specific details on the subject to be taught (Robert, 2011). Multimedia allows students to view actual objects and realistic scenes, see sequences in motion,

and to listen to narration (Nazir, Rizvi & Pujeri, 2012).

Retention was defined by Kundu and Tutoo (2002) as a preservative factor of the mind. The mind acquires the materials of knowledge through sensation and perception. These materials are preserved in the form of images for knowledge to develop and whenever a stimulating situation occurs, retained images are revived or reproduced to make memorization possible (Kurumeh & Obida, 2011). Multimedia instruction can convey information in a stimulating situation that aids the brain to preserved information in the form of images which can be easily retained and remembered. Nwanekezi and Kalu (2012) observed that students taught with multimedia instruction have high retention score than their counterpart who were taught with traditional teaching methods. This is so because multimedia has certain features that increase the receptive and memory ability of the learner. These features is focused on the ability of the learner to learn with multiple senses, thus increases student achievement and ensure learning permanency, and improvement of mental process skills that promote deeper learning which increases the rate of retention (Li, 2011; Oguz-Unver & Yurumezoglu, 2013)

Academic achievement is about how successful the learner can master the materials of the learning object (Tanah, 2009). It is the extent to which a student, teacher or institution has achieved their educational goals. Academic achievement is commonly measured by examinations or continuous assessment. It is centered on the attainment of the objectives of the content of the study. The objectives will cover cognitive, psychomotor and affective educational domains. This will further prepare the learner to acquire practical skill, scientific knowledge and attitude required as craftsmen and technicians at sub-professional level (Olaitan, 1996). Once this is achieved, the learner will be able to live well and contribute greatly to his or her society.

Hence, technical college graduates are supposed to have three options at the end of the three years program. These options according to the National Policy on Education (FRN, 2004) is to either secure employment in the industries, pursue further education in advance craft in a higher technical institutions or set up their own business and become self-employed. Unfortunately, despite all effort by the government to ensure quality educational delivery at the technical colleges failed (Peter, Abiodun & Jonathan, 2010). There have been persistent reports of high failure rate among graduates of the Technical colleges. The high failure of students in recent years according to NABTEB (2011) chief examiners' report is partly due to teaching methods employed by instructors to teach the students. In most technical colleges, teaching methods used in teaching are mostly lecture and the demonstration methods. Continued use of these traditional teaching methods reduces

the ability of students to grasp relevant concepts than when exposed to appropriate teaching techniques. The Federal Ministry of Education (2012) in her reports on TVET institutions revealed that students are always put-off or not been interested in vocational education because of the non-motivating and unchallenging methods and approach used by their teachers. Therefore, a viable instructional methods that will stimulates and motivates as well as enhancing teaching and learning should be employed. Instructional approaches that will ensure quality educational delivery and retention of what is learned need to be explored (Oshinaike & Adekunmisi, 2012). It is on this view the researcher want to investigate the effects of multimedia instruction on the retention and achievement of basic machining in mechanical craft theory in technical colleges.

In this modern age of advanced technology, the success of any educational enterprise could be measured not only in terms of how much instruction is given by teachers, but also in terms of technologies and / or media employed to ensure effective delivery and development of learners (Robert, 2011). Conventional instructional methods cannot picture clearly abstracts, difficult concepts and illustrations to the learner. In fact, the traditional technique of instruction has contributed to a lot of frustration among learners especially, the slow learners who always surrender themselves to excessive rote learning and memorization (Odo, Adenle & Okwori, 2012). It is a very difficult task for teachers to take care of each and every student in a classroom comprised of many students with individual needs. It is impossible for teachers to teach every individual according to their pace of learning and level of understanding in as limited time period. Sharma (2013) pointed out some of the things traditional method cannot achieve. He noted that teacher using traditional method cannot be able to:

- i. Provide teaching material according to the need of each student
- ii. Teach every student according to his/her own pace of learning.
- iii. Provide teaching material for as much time as the student review.
- iv. Guide the students keeping in view their individual differences.

Advancement in computer and software technology, has brought outstanding development into educational sector. Consequently multimedia instruction can be designed to take care of all the learning conditions (Gantt, 1998). Hence, there is need for technical colleges in Adamawa and Taraba states to take advantage of this technology and make use of dynamic multimedia technology to illustrate abstract concepts in

teaching cognitive and manipulative skills.

1.1. Purpose of the Study

The purpose of the study was to find out the effect of multimedia instruction on the retention and achievement of basic machining skills in mechanical craft engineering practice. Specifically, sought to find out:

1. The performance of students in cognitive skills achievement test when taught with multimedia instruction.
2. The performance of students in psychomotor achievement test when taught with demonstration instruction.
3. The retention of learning content by the students when taught with multimedia instruction.
4. The level of retention of learning object by the students when taught with demonstration instruction.

1.2. Research Questions

Two research questions were poised to guide the study as thus:

1. What is the mean performance of students in psychomotor achievement test when taught with multimedia and demonstration instruction?
2. What is the retention of the content of learning by the students when taught with multimedia and traditional instruction?

1.3. Hypotheses

Two null hypotheses were tested at 0.05 level of significance. These hypotheses includes:

H₀₁: There is no significant difference between the means performance of students taught with multimedia and demonstration instruction in psychomotor achievement test.

H₀₂: There is no significant difference between the retention of students taught with multimedia instruction and those taught with demonstration instruction.

2. Methodology

Experimental pre-test and post-test design was used for this research work. Six lessons of multimedia instruction was designed and produced by the researcher, based on 2011 NABTEB syllabus. Lesson topics includes: Workshop Safety Rules and Practice, Centre Lathe and its accessories, Cutting Fluids and Tooling Materials, Tool Shapes and their uses, Safety Measures when Working on Centre lathe as well as Basic Operations on Centre lathe. The last lesson gave instruction on basic machining processes on the centre lathe and the production of engineering component (See appendix 1). This machining process basically include: straight and step

turning, drilling, boring and counter boring, as well as grooving and taper turning.

The population of 256 students was considered for the study. This population constituted the total registered numbers of year two students in National Technical Certificate (NTC) programme in mechanical engineering craft in the four selected technical colleges in Adamawa and Taraba States.

The sample of 156 students was drawn using Yaro Yamane’s formula.

$$n = \frac{N}{1+N(e)^2}$$

n = the sample size, N = the finite population, e = level of significance (or limit of tolerable error), 1 = unity (a constant). $n = \frac{256}{1+256(0.05)^2} = 156$.

Random sampling with replacement was adopted during sample selection. The researcher asked the students to draw scraps of papers from the box. On each paper, letter A or B was written on it. Once the letter is identified, the student is asked to replace the paper back into the box. This procedure was repeated until the sample is drawn. The researcher prefers this technique because it gives individual equal chances to be selected and eliminates biases in the selection (Uzoagulu, 2011).

The instrument for data collection was the 2011 to 2013 National Business and Technical Examination Board (NABTEB) mechanical craft practice objective and practical questions with assessment profile of 40% theory and 60% practical skills, making a total of 100% gain in theoretical knowledge and practical skills. Forty objective questions was selected and used for pre-test, post-test and retention test. Practical test was used for the post test and retention test. Each objective questions carried 1 marks making a total of 40 marks. While 60 marks were awarded for the practical test, making a total of 100%. Students’ retention and achievement test was recorded and categorized into four point grade as thus: Distinction: 70 to 100%, Credit: 50 to 69%, Pass: 40 to 49%, Fail: 0 to 39%.

The test instrument was face and content validated by three experts in the Department of Technology Education, Modibbo Adama University of Technology Yola. The test instrument were not subjected to any reliability test. This is because the test questions were selected from the past NABTEB questions which was a standard instrument that had already undergone reliability test.

The researcher taught both groups by himself and administered the test instrument. The control group was taught using demonstration method of instruction. While experimental group was taught using multimedia method of instruction. At the end of the treatment, students were tested on what they were taught and what the retained. The objective

of the test instrument was to measure cognitive and psychomotor skills of the educational domains. The scores generated were used for data analysis in the study.

Method of Data Analysis

Mean and standard deviation were used to answer research questions 1 and 2 while t-test analysis was used for testing null hypotheses 1 and 2 at 0.05 level of significance.

3. Results

3.1. Research Question 1

What is the mean performance of students in psychomotor achievement test when taught with multimedia and demonstration instruction?

Table 1. Mean and Standard deviation of pre-test and post-test scores of experimental and control group in psychomotor achievement test (N= 156).

Group	Pretest			Posttest		Gain in practical Test
	N	\bar{x}_1	δ	\bar{x}_2	δ	$\bar{x}_2 - \bar{x}_1$
Experimental	80	41.26	4.15	72.15	7.29	30.89
Control	76	41.49	4.18	56.92	7.39	15.43

The data presented in Table 1 indicated that the experimental group had a mean performance of 41.26 and a standard deviation of 4.15 in the pre-test and a mean performance of 72.15 and standard deviation of 7.29 in the post-test. The result indicated that the mean differences between the post-test and pre-test ($\bar{x}_2 - \bar{x}_1$) was 30.89 in the experimental group. The control group had a mean performance of 41.49 with a standard deviation of 4.18 in the pre-test. While in the post-test, the mean performance was 56.92 and a standard deviation of 7.39. The post-test ($\bar{x}_2 - \bar{x}_1$) gain was 15.43. This implies that the experimental group performed better than the control group in practical test.

3.2. Research Question 2

What is the retention of the content of learning by the students when taught with multimedia and traditional instruction?

Table 2. Mean and Standard deviation of post-test and retention test of experimental and control group (N=156).

Group	Posttest			Retention test		Difference in posttest-pretest
	N	\bar{x}_2	δ	\bar{x}_3	δ	$\bar{x}_2 - \bar{x}_3$
Experimental	80	72.15	7.29	67.15	4.15	5
Control	76	56.92	7.39	40.97	7.39	15.95

The data presented in Table 2 indicated that the experimental group had a mean performance of 72.15 and a standard deviation of 7.29 in the post-test and a mean performance of 67.15 and standard deviation of 8.73 in the retention test. This make a loss in retention in the experimental group to be 5. The control group had a mean performance of 56.92 and a standard

deviation of 7.39 in the post-test and a mean performance of 40.97 and standard deviation of 8.42 in the retention test, loss in the retention was 15.95. This implies that the experimental group had more retention ability than the control group.

H_{01} : There is no significant difference between the mean

Table 3. T-test analysis of means scores of the posttest of students taught with multimedia and those taught with the traditional instruction in practical test.

Group	\bar{x}	δ	N	Df	Standard Error	t-cal	t-table	Decision
Experimental	72.15	7.29	80	154	1.18	12.91	1.98	Significant
Control	56.92	7.39	76					

The analysis of data in table 3 showed that t-cal (12.91) is greater than t-table (1.98). Hence the null hypothesis is rejected.

H_{02} : There is no significant difference between the retention of the content of study by students taught with multimedia and those taught with traditional instruction.

Table 4. T-test analysis of the retention of the content of study by the students taught with multimedia and those taught with demonstration instruction.

Group	\bar{x}	δ	N	Df	Standard Error	t-cal	t-table	Decision
Experimental	67.15	4.15	80	154	1.08	10.91	1.976	Significant
Control	40.79	7.39	76					

The analysis of data in table 4 showed that t-cal (12.91) is greater than t-table (1.98). Therefore the null hypothesis is rejected.

3.3. Findings

On the basis of the data collected and analyzed for this study, the following findings were made:

- i. Students taught with multimedia instruction performed higher in the post-test than those taught with Demonstration instruction, as the result of the effectiveness of the method used
- ii. There was significant difference in the retention abilities in cognitive and psychomotor skills of students taught with multimedia.
- iii. Multimedia instruction is effective on teaching cognitive skills, psychomotor skills and it consolidates retention of learning content than demonstration instruction.

4. Discussion of Findings

The results showed that the experimental group had higher mean performance than the control group in the post-test in practical test. This finding indicates that multimedia instructional has a positive effect on students' academic achievement in basic machining processes. This finding is in consonant with the works of Nazir, Rizvi, and Pujeri (2012), which found out that learning with multimedia instruction increased interest in the learner and enhances learning. This means that multimedia instructional approach is more effective than the demonstration method when it comes to developing students in handling complex tasks such as the production of engineering components. It flexibility in

performance of students taught with multimedia and demonstration instruction in psychomotor skills achievement test.

T

instructing and having more access repeated lessons make the students to learn and retain more content.

Similarly, analysis on the retention of the content of study shown that there is significant difference in the retention of content of study. The experimental group retained more content compared to the control group. This result was in accordance to the work of Nwanekezi and Kalu (2012) who found out that students taught with multimedia instruction tended to be superior to their counterparts with regard to retention in Basic Science Concepts studied. This inferred that multimedia instruction significantly improves active participants in learners and making learning more meaningful. It also connect the existing and new knowledge to consolidate learning experience.

5. Recommendations

Base on the results of these findings the following recommendations are made.

1. TVET teachers should adopt the components of multimedia instruction. This will enable them to cater for diverse learning styles of students in their classrooms as this, will improve academic achievement and development of practical skills.
2. Government should provide more funds and grants to equip laboratories, studios and workshops that will facilitate production and multimedia instruction.
3. TVET teachers should be given on-the-job training opportunities such as short-term courses, seminars and workshop to enable the teachers to update their knowledge; this will help them to constantly keep abreast with the ever-changing scientific knowledge and various modern

methods of teaching trade subjects.

6. Conclusion

Having found out that instructions with multimedia proved to be effective especially in teaching difficult and abstract concepts. It is ideal to use it in teaching courses that may not permit safe environment to the teacher and learner. It can be used where mastery of procedures is needful, and in distance learning where teacher-student personal contact is not possible. Instructing with multimedia bring the object of learning the real situation in a virtual world. Thus stimulates, motivates and enhances learning. It creates mental image in the mind of the learner, thus creating faster remembering and enhances retention of learning content. It is therefore important to adopt the use of multimedia instruction in the quest for education for all.

Base on the results of the findings of this study, the following recommendations were made.

1. TVET teachers should adopt the components of multimedia instruction. This will enable them to cater for diverse learning styles of students in their classrooms as this, will improve academic achievement and development of practical skills.
2. Government should provide more funds and grants to equip laboratories, studios and workshops that will facilitate production and multimedia instruction.
3. TVET teachers should be given on-the-job training opportunities such as short-term courses, seminars and workshop to enable the teachers to update their knowledge; this will help them to constantly keep abreast with the ever-changing scientific knowledge and various modern methods of teaching trade subjects.

Appendixes

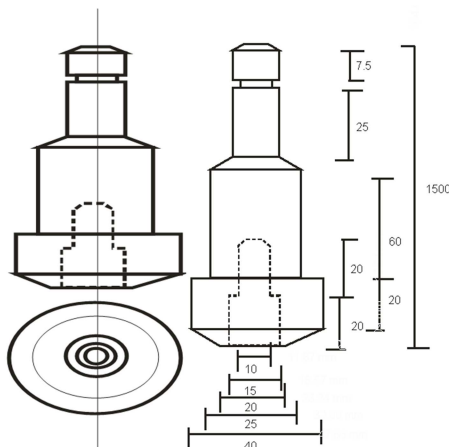

Appendix 1. Mechanical Engineering Component (Stud), Instruction: All Dimension in Millimeters.

Table 5. Sample distributions of control and experimental groups.

Schools	Experimental group	Control group	Total
GSTC Yola	20	19	39
GSTC Numan	20	19	39
GSTC Jalingo	20	19	39
GSTC Balli	20	19	39
Grand Total	80	76	156

References

- [1] Aloraini, S. (2012). The impact of using multimedia on students' academic achievement in the College of Education at King Saud University. *Journal of King Saud University Languages and Translation*, 24(2), 75-82. Retrieved from: <http://www.sciencedirect.com>
- [2] Atsumbe, B. N., Ngutor, N., Chinda, P. D. & Enoch, E. B. (2012). Information and communication technology (ICT) skills necessary by industrial technology education students in universities for effective participation in electronic learning. *Multidisciplinary Journal of Science Technology and Vocational Education*, (MJOSTEVE), 1-13.
- [3] Dankor, F. (2011). Assessment of learner acceptance and satisfaction with video-based instructional materials for teaching practical skills at a distance. *Research Article*, 12(5), 74-92. Retrieved from: <http://www.irrodl.org/index.php/irrodl/article/viewFile/953/1891>
- [4] El-Sayed & El-Sayed, (2013). Video-based lectures: An emerging paradigm for teaching human anatomy and physiology to student nurses. *Alexandria Journal of Medicine*, 49(3), 215-222.
- [5] Federal ministry of education (2012). 4 years strategic plan for the development of the education sector. Retrieved from: <http://fmi.gov.ng/wp-content/uploads/2012/08/Federal-Ministry-of-Education-4-year-Strategic-Plan-for-the-Development-of-the-Education-Sector1.pdf>
- [6] FRN, (2014). *Federal public of Nigeria*. Retrieved from: <http://www.nigeria.gov.ng/2012-10-29-11-06-21/north-east-states/ad-amawa-stat>
- [7] Gantt, P. A. (1998). Maximizing multimedia for training purposes. The Technology Source. November, 1998. Retrieved from: <http://ts.mivu.org/default.asp?show=article&id=1034>
- [8] Gertner, R. T. (2011). *The effects of multimedia technology on learning* (Doctoral dissertation, Abilene Christian University). Retrieved from: <http://www.acu.edu/technology/mobilelearning/documents/research/effects-of-technology-on-learning.pdf>
- [9] Gupta, G. & Sehgal, S. (2012). Comparative effectiveness of videotape and hand-out mode of instructions for teaching exercises: skill retention in normal children. *PediatrRheumatol Online Journal*. 10, 4. doi: 10.1186/1546-0096-10-4
- [10] Idris, A. & Rajuddin, M. R. (2012a). The influence of teaching approaches among technical and vocational education teachers towards acquisition of technical skills in Kano state-Nigeria. *Journal of Education and Practice*, 3(16)160-165.
- [11] Kundu, C. L & Tutoo, N.N (2002). Educational psychology. New Delhi: Sterling Publishers.
- [12] Mahajan, G. (2012). Multimedia in teacher education: perceptions & uses: *Journal of Education and Practice*, 3(1), 5-13. Retrieved from: <http://www.iiste.org>

- [13] Nazir, M. I. J., Rizvi, A. H. & Pujeri, R. V. (2012). Skill development in multimedia based learning environment in higher education: *An Operational Model*, 2(11), 445-461. Retrieved from: <http://www.esjournals.org>
- [14] Nwanekezi, A. U. & Kalu, N. E. (2012). Effect of multimedia on primary school pupils' retention and interest in basic science concepts. *An International Multidisciplinary Journal, Ethiopia*, 6(2), 206-214. Retrieved from: <http://dx.doi.org/10.4314/afirrev.v6i2.18>
- [15] Odo M. I., Adenle, S. O. & Okwori, R. O. (2012). Enhancing mastery of practical skills in students of vocational and technical education through activity based instruction. *Journal of Technical Education and Training*, 4(2) 21-29.
- [16] Sever, S. Oguz-Unver, A. & Yurumezoglu, K. (2013). The effective presentation of inquiry-based classroom experiments using teaching strategies that employ video and demonstration methods. *Australasian Journal of Educational Technology*, 29(3), 450-463.
- [17] Olaitan, S. O. (1996). *Vocational and technical education (issues and analysis)*. Onisha: Noble graphic press.
- [18] Oshinaike, A. B. & Adekunmisi, S. R. (2012). Use of multimedia for teaching in Nigerian university system: a case study of university of Ibadan. *Library Philosophy and Practice*. Retrieved from: <http://unllib.unl.edu/LPP/>
- [19] Peter, O. I., Abiodun, A. P. & Jonathan, O. O. (2010). Effect of constructivism instructional approach on teaching practical skills to mechanical related trade students in western Nigeria technical colleges. *International NGO Journal*, 5(3), 059-064. Retrieved from: <http://www.academicjournals.org/INGOJ>
- [20] Robert, O. O. (2011). Information and communication technology awareness among technical college teachers in Benue State, Nigeria. *International Journal of Vocational and Technical Education*, 3(6), 75-8. Retrieved from: <http://www.academicjournals.org/IJVTE>
- [21] Sharma, P. (2013). Role of interactive multimedia for enhancing students' achievement and retention. *International Women Online Journal of Distance Education*, 2(3) 12-23. Retrieved from: <http://www.wojde.org>
- [22] Udofia, A. E., Ekpo, A. B., Nsa, E. O. & Akpan, E. O. (2012). Instructional variables and students' acquisition of employable skills in vocational education in Nigerian technical colleges. *Scholarly Journal of Education*, 1(2), 13-19. Retrieved from: <http://www.scholarly-journals.com/SJE>
- [23] Uzoagulu, A. E (2011). *Practical guide to writing research project reports in tertiary institutions*. Enugu: Cheston Ltd.